

SILLS
SECTION 10



Sills and windowsill surrounds can be formed by using any of the Lite Stone Concrete Trim and Molding varieties. These parts may be affixed to the outside of a given window opening. This section deals with full sills, which are, windowsills which extend through the wall, and upon which the glazing frame is placed. There are a number of standard sill types and sizes which are available. Custom sills can be fabricated in order to meet your specific requirements.

SILLS

PRECAST CONCRETE
WINDOW SILLS FOR
8-8-16 CMU CONSTRUCTION

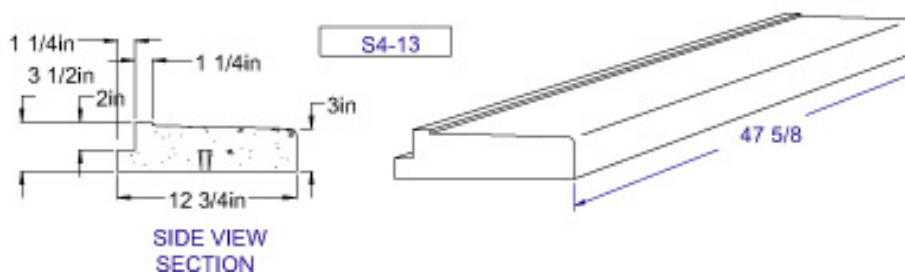
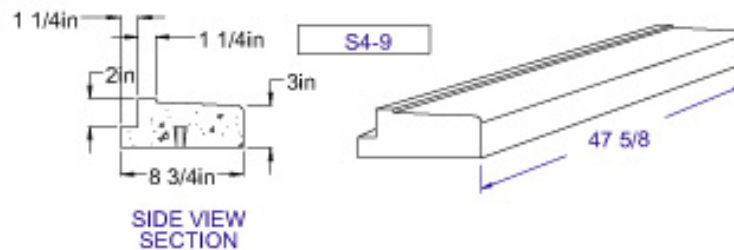
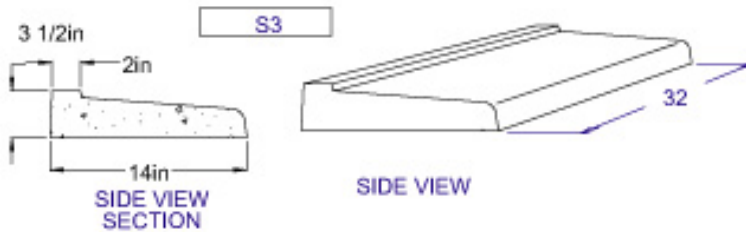
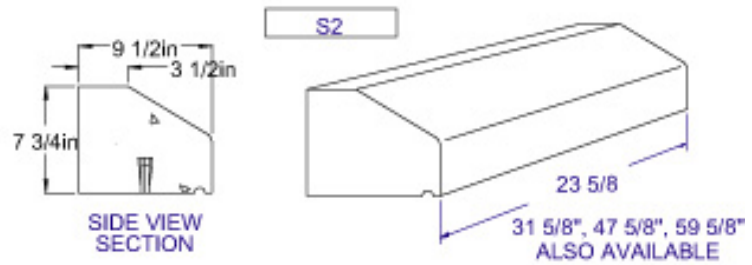
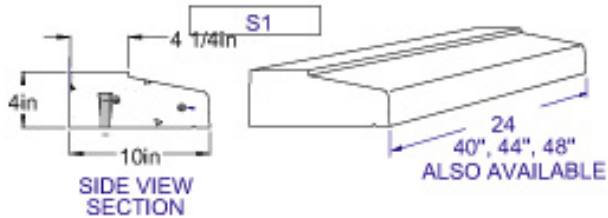

SILLS

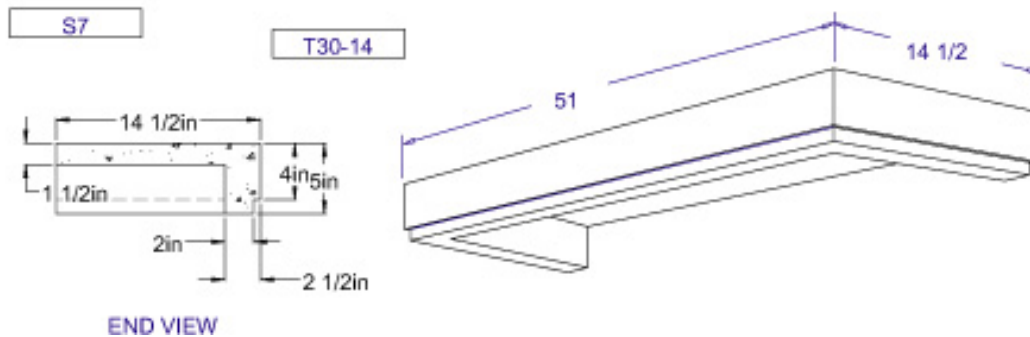
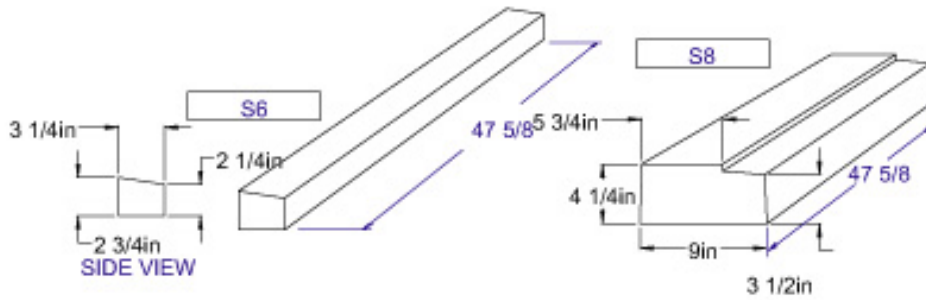
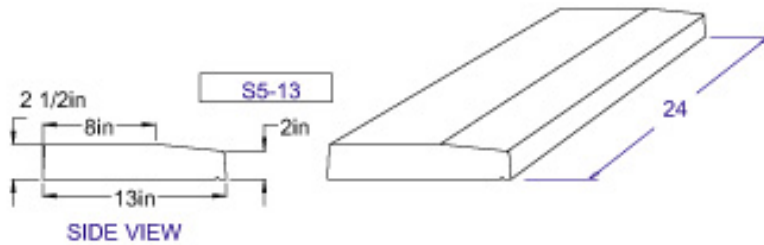
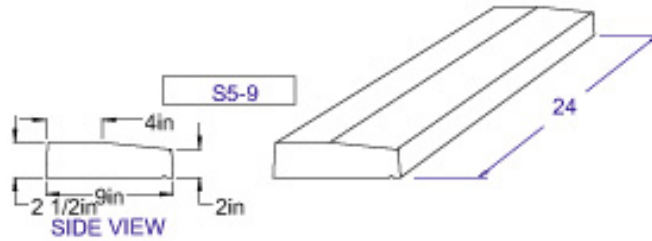

10 - 2

SILLS

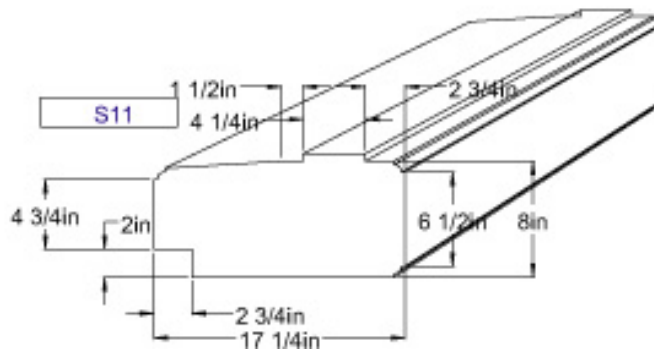
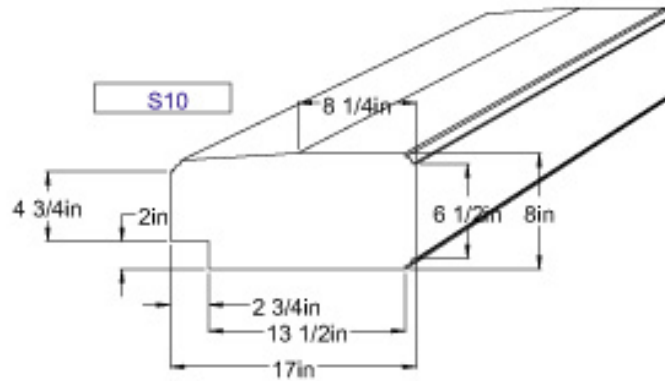
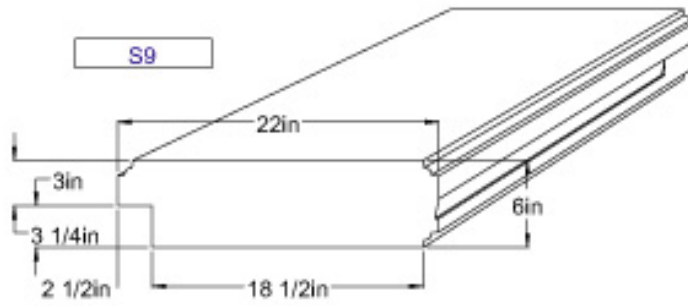

10 - 3

SILLS

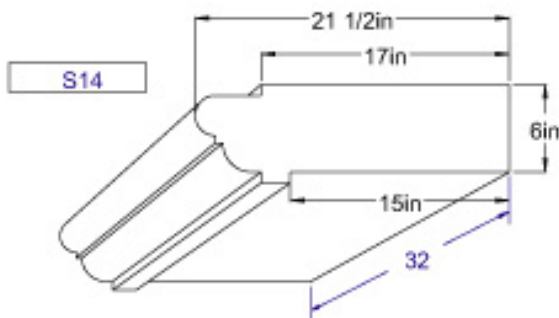
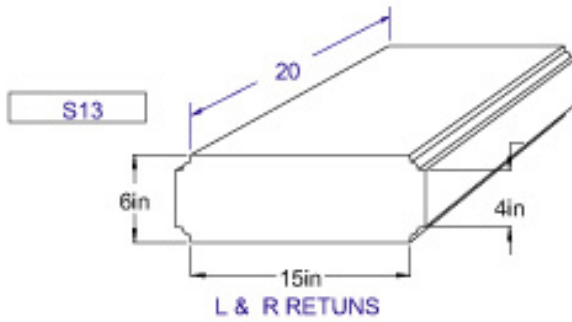
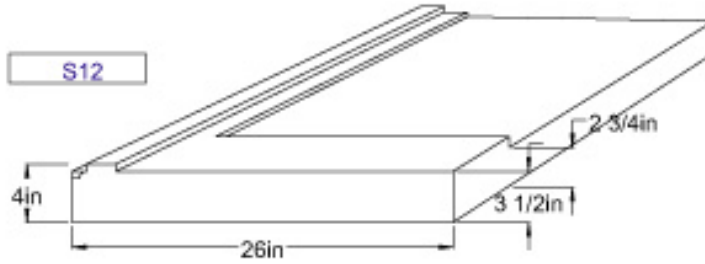

10 - 4